

FOR REFERENCE ONLY

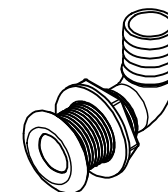
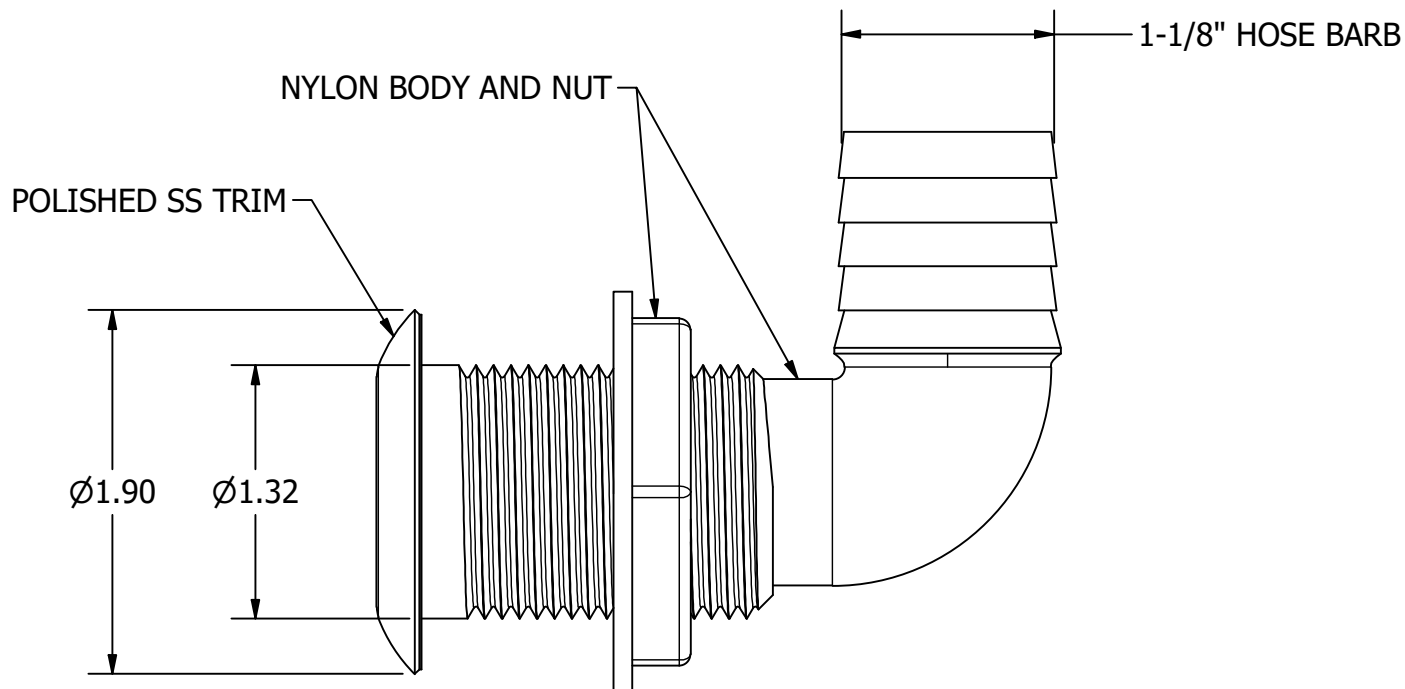

SCALE 1 : 4

UNLESS OTHERWISE SPECIFIED:
 BREAK ALL SHARP EDGES
 DIMENSIONS ARE IN INCHES
 TOLERANCES:
 FRACTIONAL: $\pm 1/16$
 DECIMAL: X.X $\pm .05$
 X.XX $\pm .01$
 X.XXX $\pm .005$
 ANGULAR: $\pm 1^\circ$
 FINISH: 120Ra

PROPRIETARY AND CONFIDENTIAL
 THE INFORMATION CONTAINED IN THIS
 DRAWING IS THE SOLE PROPERTY OF
 WHITE WATER MARINE HARDWARE. ANY
 REPRODUCTION IN PART OR AS A WHOLE
 WITHOUT WRITTEN PERMISSION IS
 PROHIBITED.



WHITE WATER
 MARINE HARDWARE

TITLE			
NYLON 90 DEG THRU-HULL W/ SS TRIM PART NUMBER: WWMH-6653N2-90			
SIZE	DWG NO	REV	
A	WWMH-6653N2-90	0	
DRAWN	KSR	7/8/2021	SCALE 1 : 1
MATERIAL			SHEET 1 OF 1