

NOTE
 316 STAINLESS STEEL
 HIGH POLISH

FOR REFERENCE ONLY

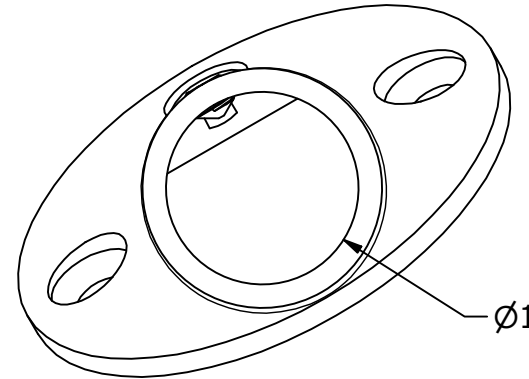

VIEW C-C
 SCALE 1 : 1

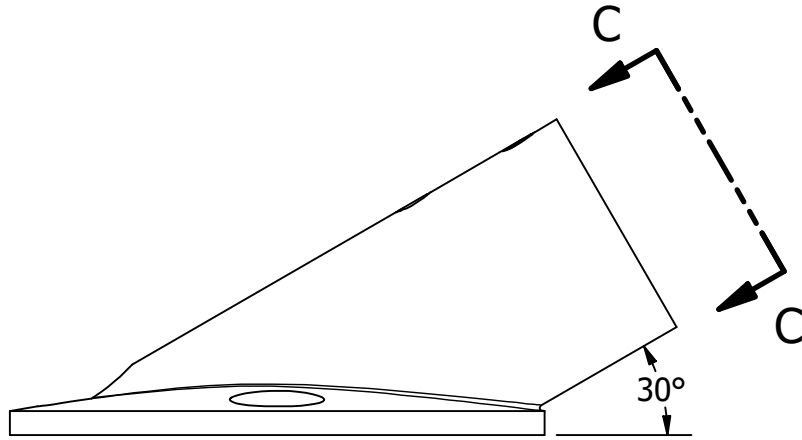
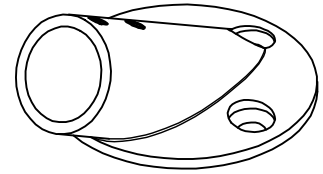
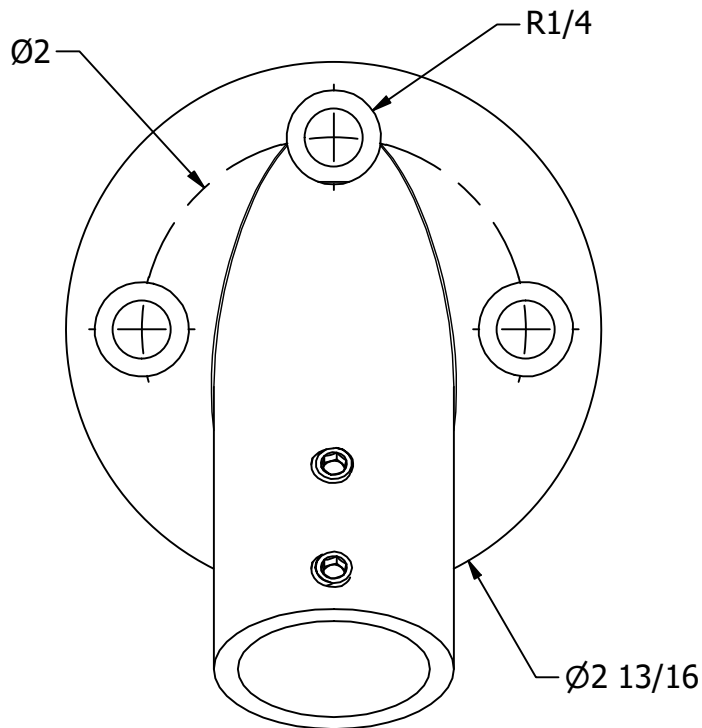

UNLESS OTHERWISE SPECIFIED:
 BREAK ALL SHARP EDGES
 DIMENSIONS ARE IN INCHES
 TOLERANCES:
 FRACTIONAL: $\pm 1/16$
 DECIMAL: X.X $\pm .05$
 X.XX $\pm .03$
 X.XXX $\pm .010$
 ANGULAR: $\pm 3^\circ$
 FINISH: 120Ra



WHITE WATER
 MARINE HARDWARE

TITLE
 ROUND RAIL BASE, 60 DEG
 PART NUMBER: 6845S

PROPRIETARY AND CONFIDENTIAL
 THE INFORMATION CONTAINED IN THIS
 DRAWING IS THE SOLE PROPERTY OF WHITE
 WATER MARINE HARDWARE. ANY REPRODUCTION
 IN PART OR AS A WHOLE WITHOUT WRITTEN
 PERMISSION IS PROHIBITED.

SIZE A	DRAWING NO. WWMH-6845S	REV 0
SCALE 1 : 1	DRAWN RC	DATE 3/12/2025
		SHEET 1 OF 1