

NOTES  
 316 STAINLESS STEEL  
 HIGH POLISH

REVISION HISTORY		
REV	DESCRIPTION	DATE
1	ADD RADIUS TO STEP PERIMETER ECN1044	9/4/25

CLEARANCE FOR  
 #12 FH SCREW

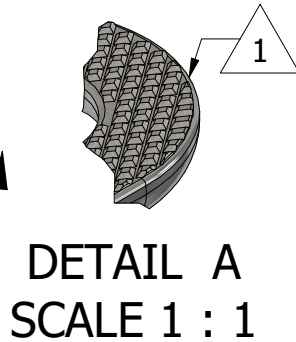
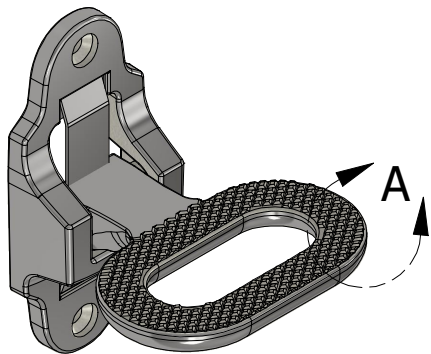
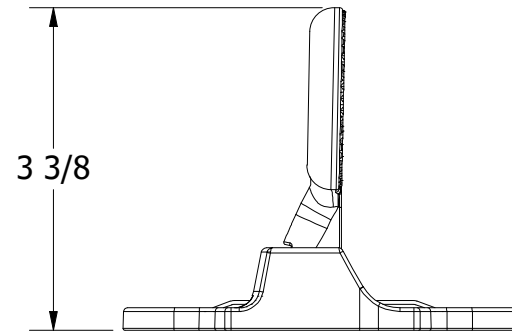
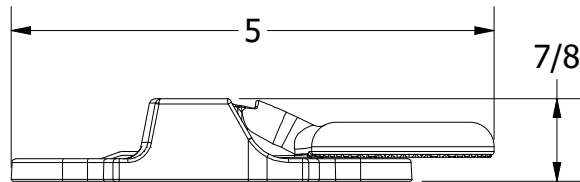
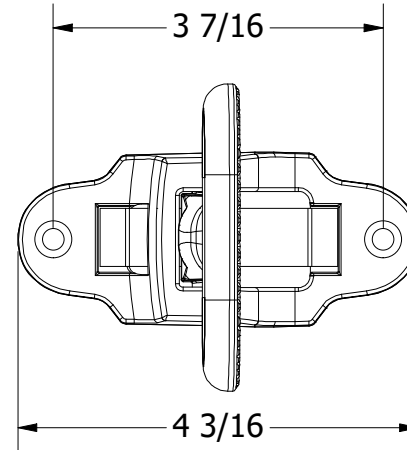
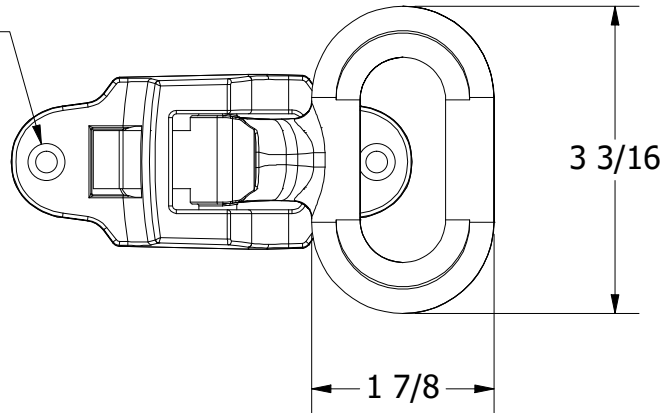

UNLESS OTHERWISE SPECIFIED:  
 BREAK ALL SHARP EDGES  
 DIMENSIONS ARE IN INCHES  
 TOLERANCES:  
 FRACTIONAL:  $\pm 1/16$   
 DECIMAL: X.X  $\pm .05$   
           X.XX  $\pm .03$   
           X.XXX  $\pm .010$   
 ANGULAR:  $\pm 3^\circ$   
 FINISH: 120Ra

**PROPRIETARY AND CONFIDENTIAL**  
 THE INFORMATION CONTAINED IN THIS  
 DRAWING IS THE SOLE PROPERTY OF WHITE  
 WATER MARINE HARDWARE. ANY REPRODUCTION  
 IN PART OR AS A WHOLE WITHOUT WRITTEN  
 PERMISSION IS PROHIBITED.



**WHITE WATER**  
 MARINE HARDWARE

TITLE

FOLDING STEP  
 PART NUMBER: 50724S

SIZE <b>A</b>	DRAWING NO. <b>WWMH-50724S</b>	REV <b>1</b>
SCALE <b>1 / 2</b>	DRAWN <b>RC</b>	DATE <b>7/18/2025</b>
SHEET <b>1</b> OF <b>1</b>		