

FOR REFERENCE ONLY

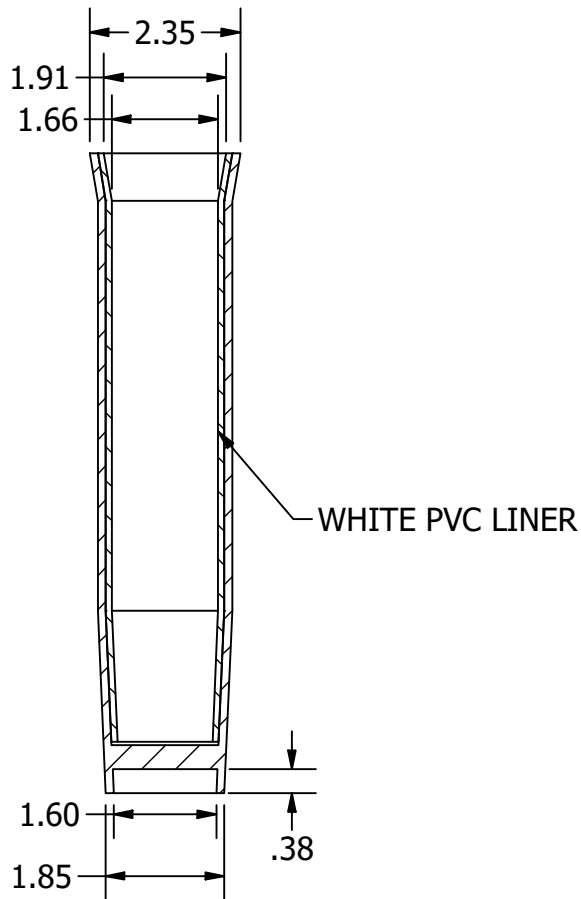

SECTION A-A
SCALE 1/3

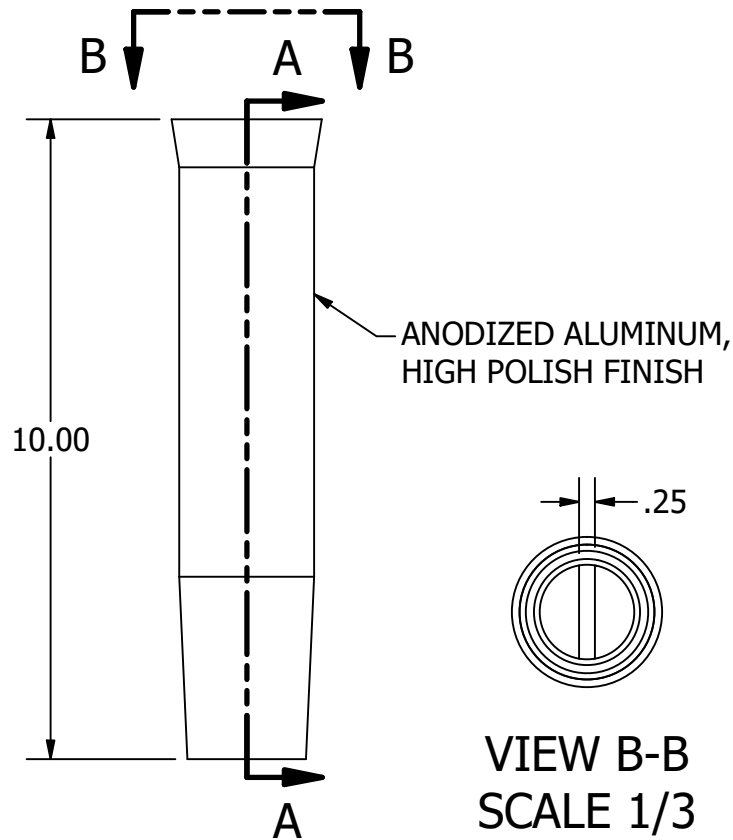

VIEW B-B
SCALE 1/3

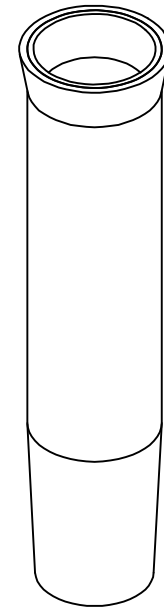

UNLESS OTHERWISE SPECIFIED:
BREAK ALL SHARP EDGES
DIMENSIONS ARE IN INCHES
TOLERANCES:
FRACTIONAL: $\pm 1/16$
DECIMAL: X.X $\pm .05$
 X.XX $\pm .01$
 X.XXX $\pm .005$
ANGULAR: $\pm 1^\circ$
FINISH: 120Ra

PROPRIETARY AND CONFIDENTIAL
THE INFORMATION CONTAINED IN THIS
DRAWING IS THE SOLE PROPERTY OF WHITE
WATER MARINE HARDWARE. ANY REPRODUCTION
IN PART OR AS A WHOLE WITHOUT WRITTEN
PERMISSION IS PROHIBITED.



WHITE WATER
MARINE HARDWARE

TITLE
ALUMINUM WELD ON ROD HOLDER 10"
PART NUMBER: 53303AL

SIZE A	DRAWING NO. WWMH-53303AL	REV 0
SCALE 1/3	DRAWN RC	DATE 8/22/2024
		SHEET 1 OF 1